

Yealink Ultra-elegant Gigabit IP Phone SIP-T46U



Yealink QUICK START GUIDE

Package Contents

The following items are included in your package. If you find anything missing, contact your system administrator.

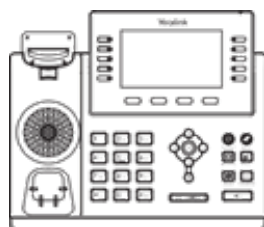

IP Phone



Handset



Handset Cord



Quick Start Guide



*Ethernet Cable
(2m CAT5E UTP Cable)*

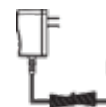

*Power Adapter
(Optional)*



Stand



*Wall Mount Bracket
(Optional)*

Note: We recommend that you use the accessories provided or approved by Yealink. The use of unapproved third-party accessories may result in reduced performance.

Assembling the Phone

1. Attach the stand, as shown below:

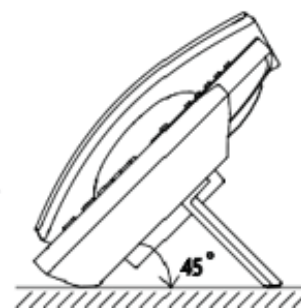
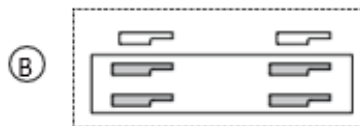
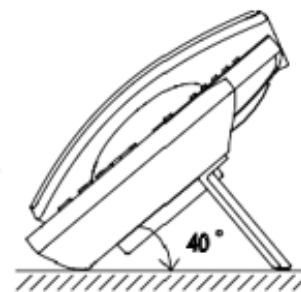
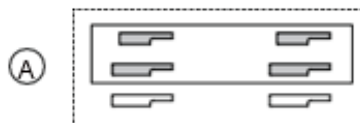
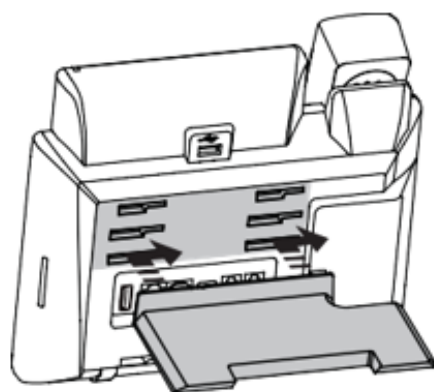

Desk Mount Method

Note: You can also mount the phone to a wall. For more information on how to attach the wall mount bracket, refer to Yealink Wall Mount Quick Installation Guide for Yealink IP Phones.

2. Connect the handset and optional headset, as shown below:

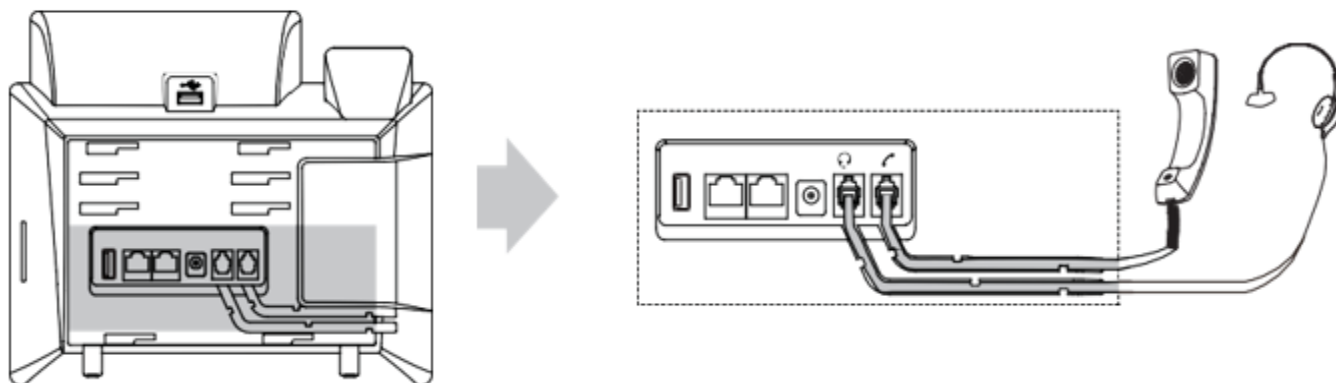

3. Connect the USB flash drive, as shown below:

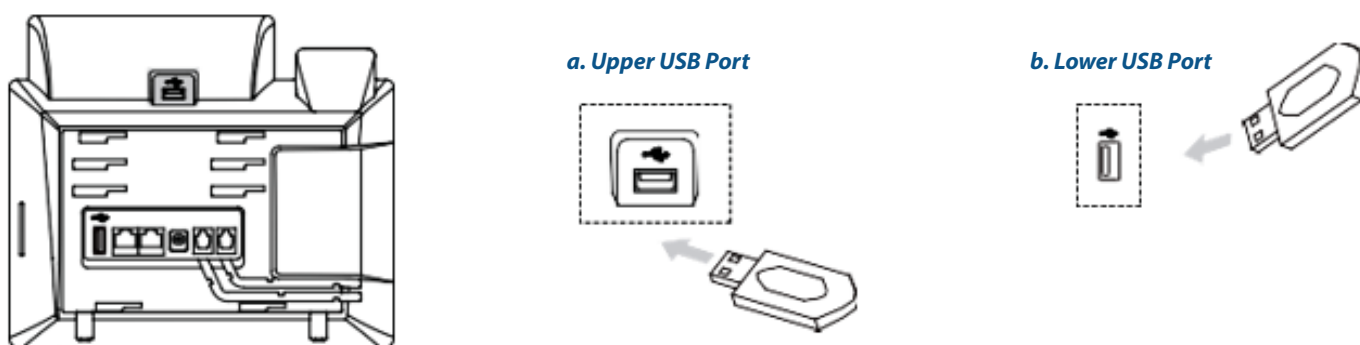

Note: The USB ports can also be used to connect other USB devices, such as EXP43, USB headset and so on. Yealink recommends that you connect Bluetooth USB dongle or Wi-Fi USB dongle to the upper USB port and connect EXP43 to the lower USB port.

4. Connect the network and power, as shown below:

You have two options for network and power connections. Your system administrator will advise you which one to use

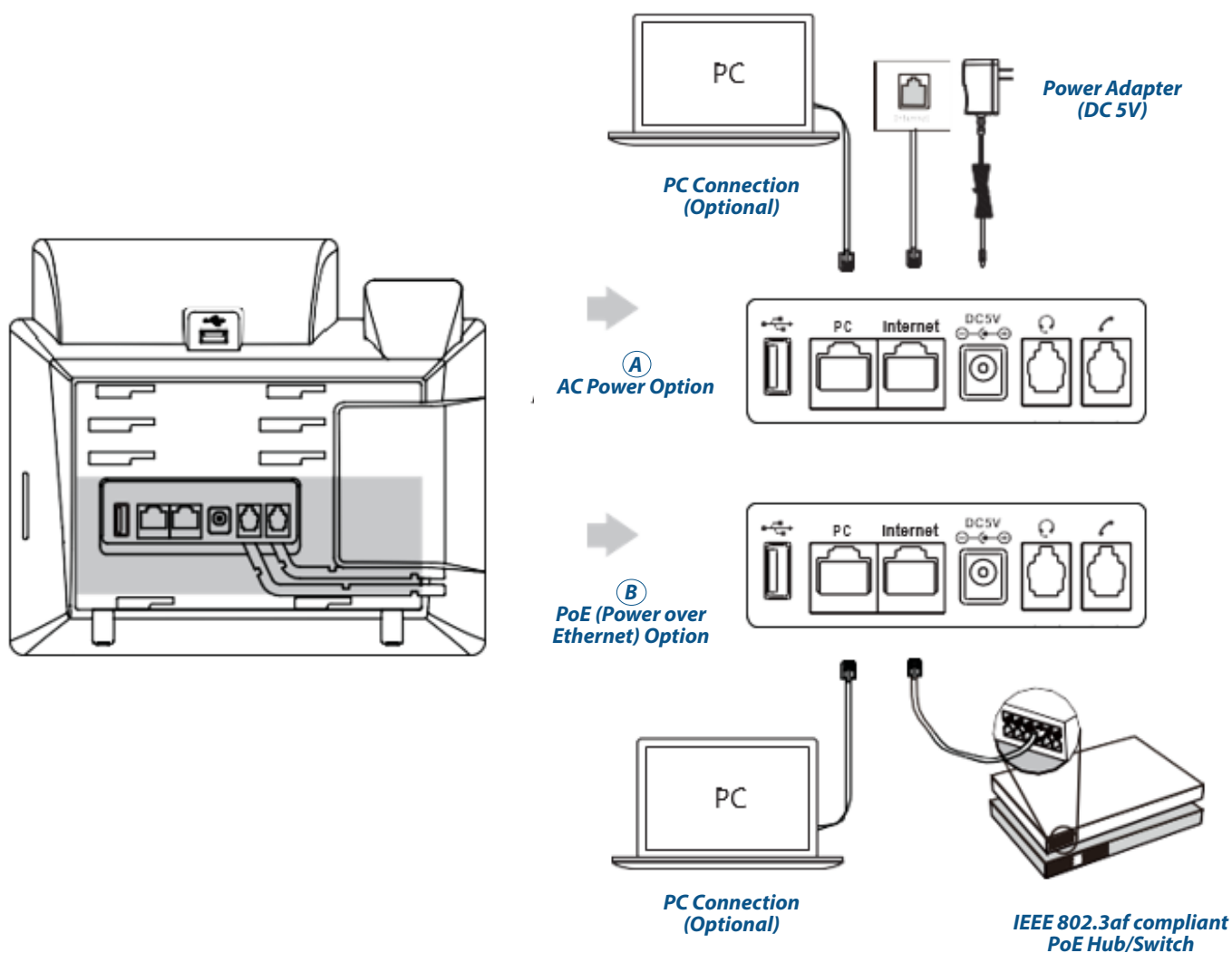

Note: The IP phone should be used with Yealink original power adapter (5V/2A) only. The use of the third-party power adapter may cause the damage to the phone. If you are connecting a PC to your phone, we recommend that you use the Ethernet cable provided by Yealink.

If inline power (PoE) is provided, you don't need to connect the power adapter. Make sure the hub/switch is PoE-compliant.

Startup

After the IP phone is connected to the network and supplied with power, it automatically begins the initialization process.

HTTP to the device with admin / admin logon, you can look up the IP address via Menu/ Status. Navigate to Settings / Auto Provision and set IPv4 Custom Option to 160.

Save the change and reboot the device.

If the connected router is not correctly configured for Airespring DHCP settings you can alternatively turn off DHCP Active and set the Provisioning Server URL manually to <https://commportal.airespring.com/sip-ps/>. Then reboot the phone.

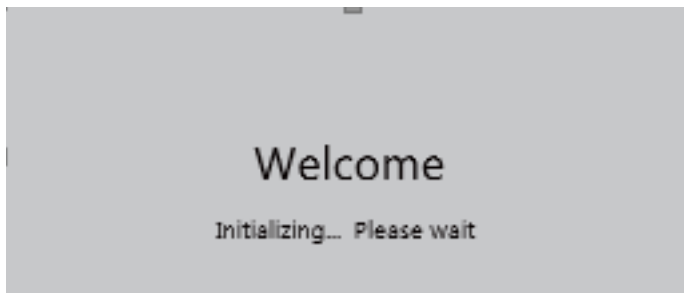

Basic Call Features

Placing a Call

Using the handset:

1. Pick up the handset.
2. Enter the number, and then press the Send soft key.

Using the speakerphone:

1. With the handset on-hook, press .
2. Enter the number, and then press the **Send** soft key.

Using the headset:

1. With the headset connected, press  to activate the headset mode.
2. Enter the number, and then press the **Send** soft key.

Note: During a call, you can alternate between the headset, hands-free speakerphone and handset modes by pressing the HEADSET key, the Speakerphone key or by picking up the handset. Headset mode requires a connected headset.

Answering a Call

Using the handset:

Pick up the handset.

Using the speakerphone:

Press .

Using the headset:

Press .

Note: You can reject an incoming call by pressing the **Reject** soft key.

Ending a Call

Using the handset:

Hang up the handset or press the **End Call** soft key.





Using the speakerphone:

Press  or the **End Call** soft Key



Using the headset:

Press the **End Call** soft key.

Redial

- ▶ Press  to enter the **Placed Calls** list, press  or  to select the desired entry, and then press  or the **Send** soft key.
- ▶ Press  twice when the phone is idle to dial out the last dialed number.

Call Mute and Un-mute





- ▶ Press  to mute the microphone during a call.
- ▶ Press  again to un-mute the call.

Call Hold and Resume

To place a call on hold:

Press  or the **Hold** soft key during an active call.



To resume the call, do one of the following:

- ▶ If there is only one call on hold, press  or the **Resume** soft key.
- ▶ If there is more than one call on hold, press  or  to select the desired call, and then press  or the **Resume** soft key.



Call Transfer

You can transfer a call in the following ways:



Blind Transfer

1. Press  or the **Transfer** soft key during an active call. The call is placed on hold.
2. Enter the number you want to transfer to.
3. Press  or the **B Transfer** soft key.

Semi-Attended Transfer

1. Press  or the **Transfer** soft key during an active call. The call is placed on hold.
2. Enter the number you want to transfer to, and then press the **Send** soft key.
3. Press  or the **Transfer** soft key when you hear the ring-back tone.

Attended Transfer

1. Press  or the **Transfer** soft key during an active call. The call is placed on hold.
2. Enter the number you want to transfer to, and then press the **Send** soft key.
3. Press  or the **Transfer** soft key when the second party answers.

Call Conference

1. Press the **Conference** soft key during an active call. The call is placed on hold.
2. Enter the number of the second party, and then press the **Send** soft key.
3. Press the **Conference** soft key again when the second party answers. All parties are now joined in the conference.
4. Press the **End Call** soft key to disconnect the main line from all parties.

Note: You can split the conference call into two individual calls by pressing the **Split** soft key.

Voice Message



If the phone is registered to more than one line the Messages button will ask the user to select the line to connect to the voicemail system with via Message Center.

To listen to voice messages:

1. Press  or the **Connect** soft key.
2. Follow the voice prompts to listen to your voice messages.

Customizing Your Phone

Call History

1. Press the **History** soft key when the phone is idle, press  or  to scroll through the list.
2. Select an entry from the list, you can do the following:
 - Press the **Send** soft key to call the entry.
 - Press the **Delete** soft key to delete the entry from the list.

If you press the **Option** soft key, you can also do the following:



- ▶ Select **Detail** to view detailed information about the entry.
- ▶ Select **Add to Contacts** to add the entry to the local directory.
- ▶ Select **Delete All** to delete all entries from the list.

Contact Directory



To add a contact:

1. Press the Directory soft key when the phone is idle, and then select **All Contacts**.
2. Press the **Add** soft key to add a contact.
3. Enter a unique contact name in the **Name** field and contact numbers in the corresponding fields.
4. Press the **Save** soft key to accept the change.

To edit a contact:





1. Press the **Directory** soft key when the phone is idle, and then select **All Contacts**.
2. Press  or  to select the desired contact, press the **Option** soft key and then select **Detail** from the prompt list.
3. Edit the contact information.
4. Press the **Save** soft key to accept the change.

To delete a contact:

1. Press the **Directory** soft key when the phone is idle, and then select **All Contacts**.
2. Press  or  to select the desired contact, press the **Option** soft key and then select **Delete** from the prompt list.
3. Press the **OK** soft key when the LCD screen prompts "Delete selected item?".

Note: You can add contacts from call history easily. For more information, refer to **Call History** above.

Volume Adjustment

- ▶ Press  during a call to adjust the receiver volume of the handset/ speakerphone/headset.
- ▶ Press  during a call to adjust the receiver volume of the handset/ speakerphone/headset. Press  when the phone is idle or ringing to adjust the ringer volume.
- ▶ Press  to adjust the media volume in the corresponding screen